



# EFXZ301-H

## 4-WHEEL LI-ION COUNTERBALANCE FORKLIFT 3.0T

3000 kg 6000 mm 80 V Li-Ion



The EFXZ Series is ideal for warehousing, logistics centers, and manufacturing sites that demand both performance and sustainability. Its pneumatic tires and robust steel chassis provide exceptional stability for indoor and outdoor operations. The remanufactured IC base ensures strength, while the Li-ion power system offers long runtime, fast charging, and reduced maintenance. Available with multiple mast configurations and customizable fork dimensions, the EFXZ series adapts easily to diverse material handling tasks, from pallet transport to high stacking in industrial environments.

SPECIFICATION	REF	UNIT	VALUE
Battery type			Li-Ion
Battery nominal capacity K5		Ah	205
Battery voltage		V	80
Rated capacity	Q	kg	3000
Load centre distance	c	mm	500
Service weight		kg	4200
Height, mast lowered	$h_1$	mm	2100
Lift	$h_3$	mm	3000
Height, mast extended	$h_4$	mm	4110
Overall length	$l_1$	mm	3730
Overall width	$b_1/b_2$	mm	1225
Length to face of forks	$l_2$	mm	2690
Fork dimensions	s/e/l	mm	45×122×1070
Turning radius	Wa	mm	2400
Manufacturer			EP
Model designation			EFXZ-301-H

# Features

## Comprehensive remanufacturing process

Each EFXZ truck is completely disassembled, inspected, and rebuilt in EP's remanufacturing facility. Critical components such as the chassis, front axle, and counterweight are refurbished, while the powertrain is replaced with a state-of-the-art lithium-ion system. This ensures the forklift delivers like-new reliability with a fraction of the cost and environmental impact.



## Advanced Li-ion technology for maximum efficiency

The EFXZ is powered by EP's 80V Li-ion battery, available in 150Ah to 410Ah configurations. The lithium system offers fast and opportunity charging, zero maintenance, and consistent power output. Combined with PMSM motors, it provides smoother acceleration, reduced noise, and higher energy efficiency compared to IC models.



## Rugged performance with renewed reliability

With load capacities up to 3 tons, travel speeds of 12 km/h, and gradeability up to 20%, the EFXZ performs effortlessly across demanding applications. Its pneumatic tires, reinforced frame, and hydraulic braking system ensure dependable operation on uneven floors and outdoor terrains, meeting the same performance and safety standards as new forklifts.





## Sustainable and cost-effective material handling

By reusing IC forklift structures and converting them to electric power, the EFXZ Series reduces manufacturing waste and CO<sub>2</sub> emissions. It offers up to 40% lower operational costs, extended service life, and full EP warranty coverage, making it a responsible and economical alternative for fleet upgrades.

## VDI Chart

	SPECIFICATION	REF	UNIT	VALUE
1.1	Manufacturer			EP
1.2	Model designation			EFXZ-301-H
1.3	Drive			Electric
1.4	Operator type			Seated
1.5	Rated capacity	Q	kg	3000
1.6	Load centre distance	c	mm	500
1.8	Load distance, centre of drive axle to fork	x	mm	481
1.9	Wheelbase	y	mm	1750
2.1	Service weight		kg	4200
2.2	Axle loading, laden front/rear		kg	6374/868
2.3	Axle loading, unladen front/rear		kg	1642/2530
3.1	Tyres			Pneumatic
3.2	Tyre size, front		mm	28X9-15-14PR
3.3	Tyre size, rear		mm	6.50-10-10PR
3.5	Wheels, number front/rear (x=drive wheels)			2x/2
3.6	Tread width, front	b <sub>10</sub>	mm	1000
3.7	Tread width, rear	b <sub>11</sub>	mm	980
4.1	Tilt of mast/fork carriage forward/backward		°	6/12
4.2	Height, mast lowered	h <sub>1</sub>	mm	2100
4.3	Free lift	h <sub>2</sub>	mm	120
4.4	Lift	h <sub>3</sub>	mm	3000
4.5	Height, mast extended	h <sub>4</sub>	mm	4110

	SPECIFICATION	REF	UNIT	VALUE
4.7	Height of overhead guard (cabin)	h6	mm	2170
4.8	Seat height relating to SIP/stand height	h7	mm	1115
4.12	Coupling height	h10	mm	340
4.19	Overall length	l <sub>1</sub>	mm	3730
4.20	Length to face of forks	l <sub>2</sub>	mm	2690
4.21	Overall width	b <sub>1</sub> /b <sub>2</sub>	mm	1225
4.22	Fork dimensions	s/e/l	mm	45×122×1070
4.23	Fork carriage ISO 2328, class/type A, B			3A
4.24	Fork carriage width		mm	1145
4.31	Ground clearance, laden, below mast		mm	150
4.32	Ground clearance, centre of wheelbase	m <sub>2</sub>	mm	200
4.34.1	Aisle width for pallets 1000×1200 crossways	Ast	mm	4170
4.34.2	Aisle width for pallets 800 × 1200 lengthways	Ast	mm	4098
4.35	Turning radius	Wa	mm	2400
5.1	Travel speed, laden/unladen		km/h	11/12
5.2	Lift speed, laden/unladen		m/s	0.26/0.36
5.3	Lowering speed, laden/unladen		m/s	0.4/0.43
5.8	Max. gradeability, laden/unladen		%	15/24
5.10	Service brake			Hydraulic
5.11	Parking brake			Mechanical
6.1	Drive motor rating S2 60 min		kW	10
6.2	Lift motor rating at S3 15%		kW	16
6.4	Battery nominal capacity K5		Ah	205
6.4	Battery voltage		V	80
6.4.1	Battery type			Li-Ion
8.1	Type of drive unit			AC
10.5	Steering design			Hydraulic
10.7	Sound pressure level at the driver's seat		dB(A)	<74

## RATED CAPACITIES AND LOAD CENTERES GRAPH

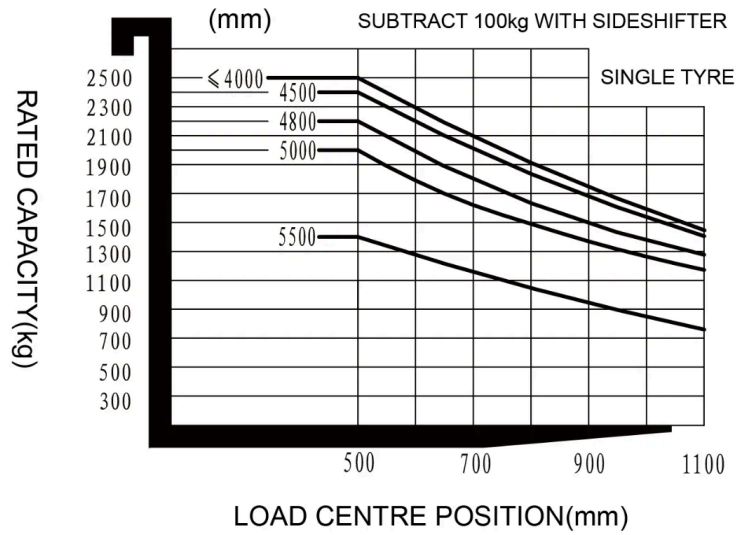

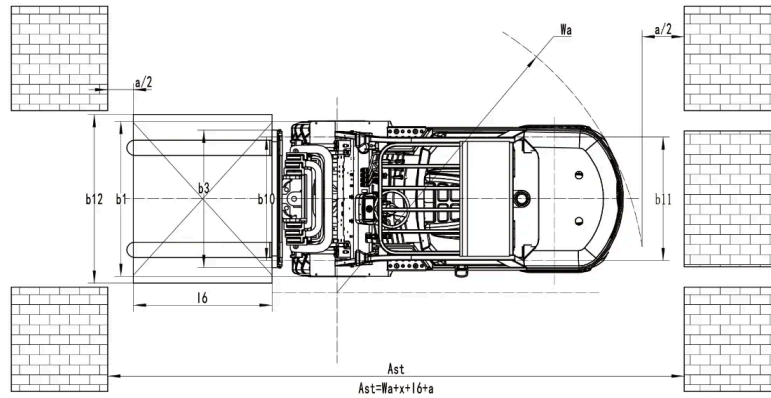
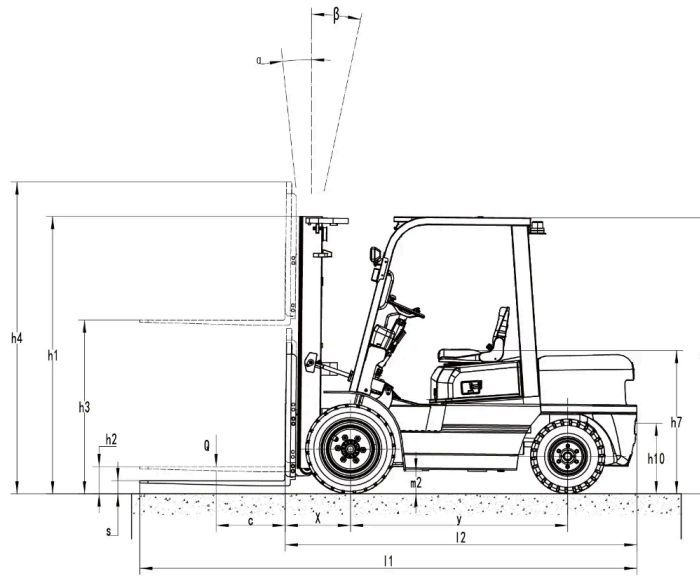

## Mast Options

MAST TYPE	LIFT HEIGHT (H3, MM)	MAST LOWERED HEIGHT (H1, MM)	MAST EXTENDED HEIGHT, NO BACKREST (H4, MM)	MAST EXTENDED HEIGHT, WITH BACKREST (H4, MM)	FREE LIFT HEIGHT, NO BACKREST (H2, MM)	FREE LIFT HEIGHT, WITH BACKREST (H2, MM)
2-Standard Mast	2700	1910	3330	3795	120	120
2-Standard Mast	3000	2060	3630	4095	120	120
2-Standard Mast	3300	2210	3930	4395	120	120

MAST TYPE	LIFT HEIGHT (H3, MM)	MAST LOWERED HEIGHT (H1, MM)	MAST EXTENDED HEIGHT, NO BACKREST (H4, MM)	MAST EXTENDED HEIGHT, WITH BACKREST (H4, MM)	FREE LIFT HEIGHT, NO BACKREST (H2, MM)	FREE LIFT HEIGHT, WITH BACKREST (H2, MM)
2-Standard Mast	3500	2310	4130	4595	120	120
2-Standard Mast	3600	2360	4230	4695	120	120
2-Standard Mast	4000	2610	4630	5095	120	120
2-Standard Mast	4300	2760	4930	5395	120	120
2-Standard Mast	4500	2860	5130	5595	120	120
2-Free Mast	3000	2040	3630	4095	1410	945
2-Free Mast	3300	2190	3930	4395	1560	1095
2-Free Mast	3600	2340	4230	4695	1710	1245
3-Free Mast	4300	2040	4930	5395	1410	945
3-Free Mast	4500	2120	5130	5595	1490	1025
3-Free Mast	4800	2225	5430	5895	1595	1130
3-Free Mast	5000	2310	5630	6095	1680	1215
3-Free Mast	5500	2560	6130	6595	1930	1465
3-Free Mast	6000	2810	6630	7095	2180	1715

## Options

ITEM	OPTIONS (optional items marked in yellow)
Fork dimension	122*45*1070   122*45*1150   122*45*1220   122*45*1370   122*45*1520   122*45*1600   122*45*1700   122*45*1820   122*45*2000   122*45*2200   122*45*2400
Fork carriage width option	1100mm   Yes and not customized
Backrest height	1095mm   Yes and not customized
Front wheel material	Pneumatic   Normal solid   Non-marking solid
Rear wheel material	Pneumatic   Normal solid   Non-marking solid
Battery capacity	80V205AH   80V280AH   80V410AH
Charger	80V35A internal   80V60A Integrated   80V60A external   80V100A external   80V150A external   80V200A external (410Ah only)
Battery display indicator (BDI)	With hourmeter (Bluetooth) without ESP

ITEM	OPTIONS (optional items marked in yellow)
Seat type	Regular   Regular+safety belt logic switch   Comfortable   comfortable + safety belt logic switch   Suspension without armrest   Suspension without armrest+ safety belt logic switch   Suspension with armrest+ safety belt logic switch
Attachments	No   Built-in sidsifter   External shifter   Fork positioner with sidsift
Traction pin	Yes
Anti-static chain	Yes and not customized
Front lamp	LED
Rear lamp	No   LED
Warning lamp	Yes and not customized
Steering lamp	LED
Blue lamp	Rear   Front and rear
Area warning lamp	No   Both sides   Both sides and rear
Rearview mirror	One in front   Two on sides and one in front
Buzzer	Yes and not customized
OPS system	No   Yes and not customized
USB interface	USB with Type A ports
Telematics	Yes
Cabin	No   Basic half cabin   Upgrade half cabin   Fully enclosed cabin
Overhead guard	With tempered glass
Turn speed control	No
Heating system during lithium battery charging	No   Yes and not customized
Operator identification device	No   Card reader
Lifting electronic limit	No
Hydraulic control	Mechanical lever
Wiper water unit	Yes , only with cabin